



Lights the way to safety



SP SERIES

High-Performance
Industrial
Emergency **LED**
Lighting



The **SP Series** offers many advantages for emergency lighting needed in an industrial environment



Illuminates wide, open areas such as warehouses, manufacturing facilities and industrial corridors

Up to 25 ft mounting height with 120 ft center-to-center spacing (for a path of egress 6 feet wide meeting Life Safety Code section 7.9.2 Performance System).

Stands up to the harshest of environments with a tough NEMA 4X housing and cold weather (-40°F/-40°C) option

In areas where liquid or windblown dust are a concern, the tough NEMA 4X housing offers industrial-grade protection in applications such as hose-down areas. The cold weather option (CW4) is ideal for cold storage facilities and other freezing environments -40°F to 122°F (-40°C to 50°C). All outside hardware is stainless steel for maximum durability.



Industrial space, 200ft x 200ft x 30ft ceiling height.
Reflectances 10 / 10 / 10

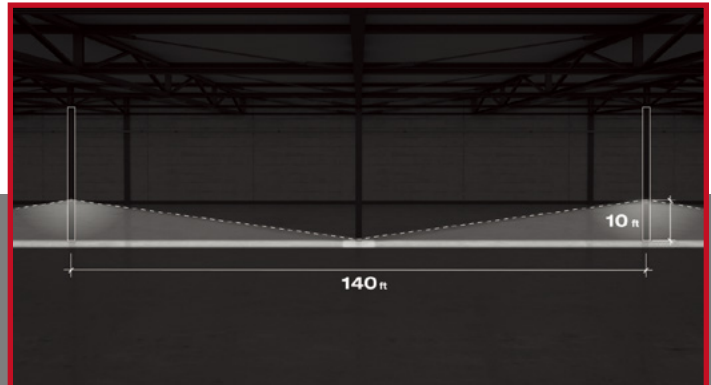

installed at 10ft in the center of the space,
the spacing is at 140ft

SP Series



Mounts easily on walls, poles, columns and struts

A separate mounting bracket allows easy installation on poles or columns. All units include a choice of 2 plugged conduit entries for wiring, one on the top and another on the side. Entries allow for 1/2 inch conduit.

Long Life LED heads with superior lumen output and smaller wattage draw allows for less units in a space, reducing maintenance upkeep

High-efficiency LEDs out-perform halogen lamps while using less battery capacity to do so.

A 15W LED provides 1300 lumens, out-performing a 50W MR16-IR halogen. Such a high lumen output with low energy requirements means that less power is needed when using LEDs also one 90W additional battery unit (**SP24N9** model) can power two remote units with two 15W dual-head LEDs on each, giving an excellent remote to battery unit ratio. Fewer battery units makes installation easier and reduces the number of units requiring testing and maintenance lowering total cost of ownership.

All battery units have Improved Diagnostics and an infrared remote test control. The universal remote test control allows each battery unit to be tested from up to 30 ft away without climbing a ladder for faster, easier compliance with required testing.

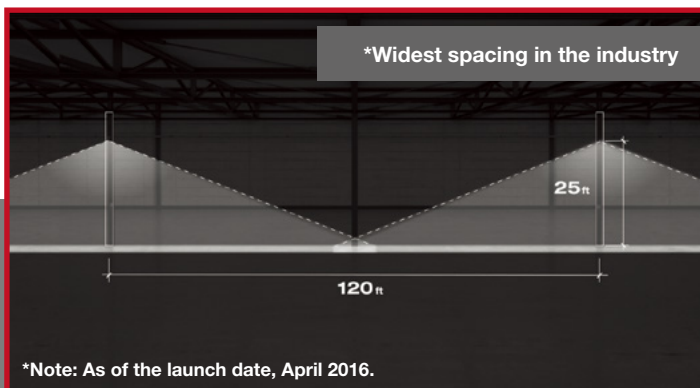

installed at 25ft in the center of the space, the spacing is at 120ft. Refer to photometry performance chart for other mounting heights and spacing



Eliminate the manual testing requirements with Nexus®



SP SERIES

**NEMA-4X, High-Performance
Industrial Battery Unit for Indoor or
Outdoor Applications**

FEATURES

Housing

- Fiberglass gray housing with captive stainless screws, Die-Cast aluminum heads. It is designed for heavy-duty industrial applications: indoors, outdoors, hose-down areas, cold-storage facilities, etc
- NEMA-4X protection grade against liquids and windblown dust
- Compact size: 0.46 cubic feet
- All external fasteners and hardware are constructed of stainless steel

Mounting

- Simple and easy to install on walls, poles, columns, struts also on vertical position for poles or columns by using mounting bracket (order separately catalog number: PMK1-L)
- May be wired from top or side (see dimensions for position) using conduit (1/2" NPT)

Performance

- High Temperature Lead-Calcium Battery operates 32°F to 122°F (0°C to 50°C) and Nickel-Cadmium Battery operates 50°F to 104°F (10°C to 40°C) ; optional cold-weather -40°F to 122°F (-40°C to 50°C)
- 6W (L6 lamp suffix), 10W (L10 lamp suffix) and 15W (L15 lamp suffix) high- efficacy LED emergency heads outperform traditional 50W MR16-IR Halogen
- Innovative head design: four-LED and dual-driver provide illumination even in case of unexpected component failure

Testing Option

- Non-Audible Improved Self-Testing Improved Diagnostics standard in all models
- Optional NEXUS® central monitoring system

Approval

- UL924 Listed

Warranty (subject to proper installation and maintenance)

- Unit has 5 year limited warranty

Detailed warranty terms located at: <http://www.lightalarms.com>

POWER CONSUMPTION CHART: maximum current draw

TEMPERATURE	SPECS
Standard temperature range	120/277VAC, 60Hz, 0.30/0.15A
Cold-Weather option	120/277VAC, 60Hz, 0.70/0.35A

UNIT RATING CHART

SERIES	DC SPECS			
	87.5% BATTERY CAPACITY (IN WATTS)			
	90 MIN.	2 HRS.	3 HRS.	4 HRS.
SP12G3	30	20	15	10
SP12G6	60	40	30	20
SP12N4	40	36	24	18
SP24N9	90	72	48	36

Note: the cold-weather option is only rated for 90 minutes.

REMOTE TEST CONTROL (included with unit)



Standard infrared remote test control included in all models: allow to test the equipment without need to climb a ladder. Functional up to 30 ft distance. Universal, one Remote Test Control may test all units on the job

SPECIFICATIONS

Supply and install **Lightalarms® SP Series** of battery unit equipment. The unit enclosure shall have a compression-molded fiberglass construction and shall be equipped with a hinged, overlapping cover. The cover shall include a 3/16" wide rubber gasket and shall fasten with two stainless-steel captive screws. The enclosure shall have lateral flanges with holes for easy installation on the wall and also include two water-tight plugs of size 1/2" NPT for vertical and horizontal conduit and wire access. The emergency lighting heads shall be installed at the bottom of the cabinet and have the electrical cable passing through the swivel via water-tight bushings. The heads shall be made of die-cast aluminum and have a flat square lens made of UV-stabilized clear polycarbonate. The lens shall be sealed with a rubber gasket and be fixed with an aluminum frame and 6 (six) tamper-proof screws. Each head shall include four (4) LED lamps and two independent LED drivers with electrical connections allowing for lighting even in case of unexpected component failure. Each head shall have an input voltage range of 12 – 24VDC and a constant power regulation, providing stable illumination during variations of the battery discharge voltage.

The equipment shall have a dual AC input rated 120/277VAC 60Hz and a charger module equipped with micro-controller and solid-state transfer relay. The charger shall perform functions like: AC brownout detection, battery lockout, low-voltage battery disconnect, and provide protection against over-current, short-circuit, and DC reverse polarity.

When specified, the equipment with Improved Diagnostic option shall execute automatic tests for one minute every 30 days, 30 minutes every sixth month and 90 minutes every 12 months. In case of functional failure detection the equipment pilot light shall change color from green to red and signal a service alarm with specific flashing codes: battery or lamp disconnect, battery failure, charger failure, lamp failure. A label installed outside on the cover shall contain the legend with diagnostic codes.

The equipment shall come standard with an infrared remote test control.

The equipment shall be rated NEMA-4X for hose-down applications. The equipment shall be listed to UL924 standards for Damp and Wet Locations.

Unit shall be **Lightalarms®** catalog number _____.

TYPE _____
 CATALOG # _____

 NOTES _____

SP SERIES

NEMA-4X, High-Performance
 Industrial Battery Unit for Indoor or
 Outdoor Applications



DIMENSIONS

Dimensions are approximate and subject to change.

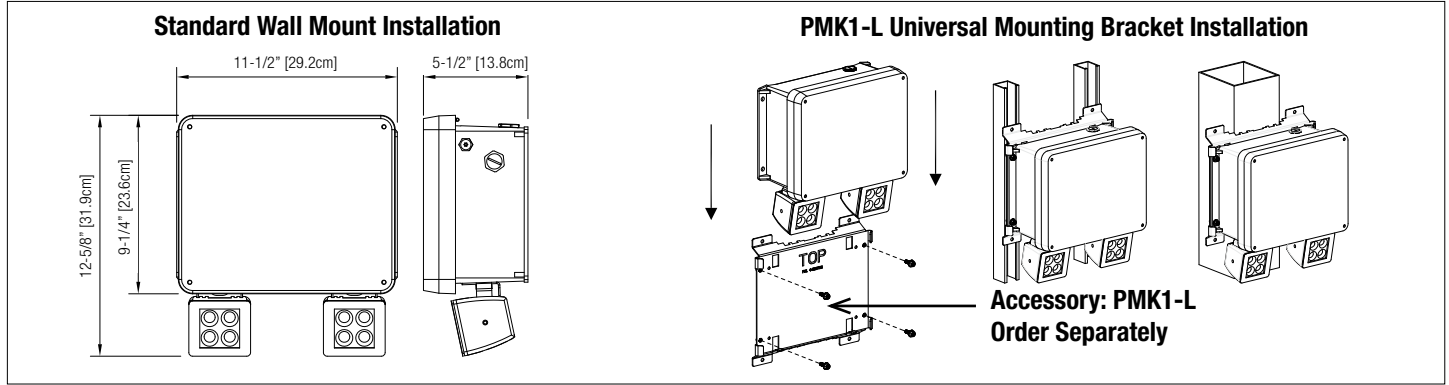

PHOTOMETRY PERFORMANCE

Capable of being installed indoors or outdoors, the SP Series of LED emergency lights deliver a stable and consistent illumination on the path of egress for a wide range of mounting heights. Depending on the required illumination levels need for the application, one choose between three level of lumen output using a 6W, 10W or 15W head. See cross reference to traditional MR16 Halogen Emergency Lamps types.

LED HEAD	POWER	TOTAL LUMENS	OUT-PERFORM SPACING OF MR16 HALOGEN LAMP TYPES
L6	6W	565	37W PAR36, MR16 Halogen (700 Lumens)
L10	10W	1000	50W PAR36, MR16 Halogen (950 Lumens)
L15	15W	1300	50W MR16-IR Halogen (1550 Lumens)

Industrial environment: wall mounted equipment, reflectances: 10/10/10; 6-ft wide illumination path.
 Illumination as per NFPA101; Average: 1fc; Min: 0.1fc; Max/min < 40:1

MOUNTING HEIGHT	SPACING CENTER-TO-CENTER (FEET)		
	LAMP L6 / 6W, 565LM	LAMP L10 / 10W, 1000LM	LAMP L15 / 15W, 1300LM
10 ft	80*	110*	140*
15 ft	70*	105*	135*
20 ft	60*	100*	130*
25 ft	50*	95*	120*

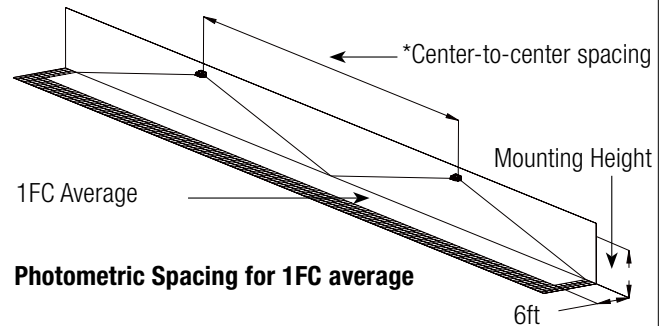

ORDERING FORMAT

SERIES	BATTERY TYPE AND CAPACITY	# OF HEADS	LED HEADS ¹	DIAGNOSTIC	OPTIONS
SP12= Severe Performance	High Temperature Lead-Calcium G3= 12V-30W, High temperature Lead-Calcium battery, Temperature= 32°F to 122°F [0...50°C] G6= 12V-60W, High temperature Lead-Calcium battery, Temperature= 32°F to 122°F [0...50°C] Nickel-Cadmium N4= 12V-40W, Nickel-Cadmium battery, Temperature= 50°F to 104°F [10...40°C] N9= 24V-90W, Nickel-Cadmium battery, Temperature= 50°F to 104°F [10...40°C]	0= No head 1= One head 2= Two heads	L6= 12-24V, 6W (565 Lumens) L10= 12-24V, 10W (1000 Lumens) L15= 12-24V, 15W (1300 Lumens)	Standard Diagnostic IDNA= Improved Diagnostic, non-audible Optional Diagnostic ID= Improved Diagnostic, audible NEX= NEXUS® wired NEXRF= NEXUS® wireless	CW4= Cold-Weather -40°F [-40°C] ¹ T3= Time Delay 15 minutes RFI= Radio frequency interference filter
SP24= Severe Performance					

EXAMPLE: SP12N42L6IDNARFI

SPR SERIES REMOTE FIXTURE

NEMA-4X, High-Performance Remote for
Indoor or Outdoor Applications

TYPE _____

CATALOG # _____

NOTES _____

FEATURES

Housing

- Die-Cast gray housing and heads designed for heavy-duty industrial applications: indoors, outdoors, hose-down areas, cold-storage facilities, etc
- NEMA-4X protection grade against liquids and windblown dust
- All external fasteners and hardware are constructed of stainless steel

Mounting

- Can be installed in wide temperature range: -40°F to 131°F (-40°C to 55°C)
- Simple and easy to install on walls, poles, columns, struts, also on vertical position for poles or columns by using mounting bracket (order separately catalog number: PMK1-L)
- May be wired from top or side (see dimensions for position) using conduit (1/2" NPT)

Performance

- 10W (L10 lamp suffix) and 15W (L15 lamp suffix) high-efficacy LED emergency heads outperform traditional 50W MR16-IR Halogen
- Innovative head design: four-LED and dual-driver provide illumination even in case of unexpected component failure

Approval

- UL924 Listed

Warranty (subject to proper installation and maintenance)

- Unit has a five year limited warranty
- Detailed warranty terms located at: <http://www.lightalarms.com>

DIMENSIONS

Dimensions are approximate and subject to change.

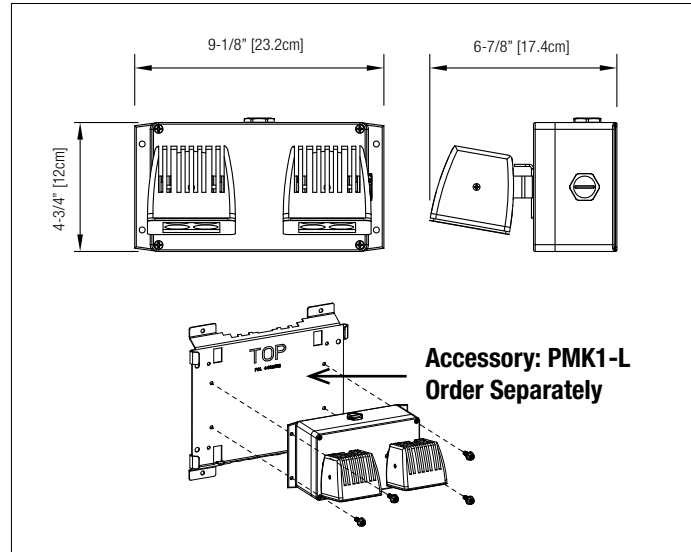

PHOTOMETRY PERFORMANCE

Capable of being installed indoors or outdoors, the SP Series of LED emergency lights deliver a stable and consistent illumination on the path of egress for a wide range of mounting heights. Depending on the required illumination levels need for the application, one choose between three level of lumen output using a 6W, 10W or 15W head. See cross reference to traditional MR16 Halogen Emergency Lamps types.

LED HEAD	POWER	TOTAL LUMENS	OUT-PERFORM SPACING OF MR16 HALOGEN LAMP TYPES
L6	6W	565	37W PAR36, MR16 Halogen (700 Lumens)
L10	10W	1000	50W PAR36, MR16 Halogen (950 Lumens)
L15	15W	1300	50W MR16-IR Halogen (1550 Lumens)

Industrial environment: wall mounted equipment, reflectances: 10/10/10; 6-ft wide illumination path.
Illumination as per NFPA101; Average: 1fc; Min: 0.1fc; Max/min < 40:1

SPACING CENTER-TO-CENTER (FEET)			
MOUNTING HEIGHT	LAMP L6 / 6W, 565LM	LAMP L10 / 10W, 1000LM	LAMP L15 / 15W, 1300LM
10 ft	80*	110*	140*
15 ft	70*	105*	135*
20 ft	60*	100*	130*
25 ft	50*	95*	120*

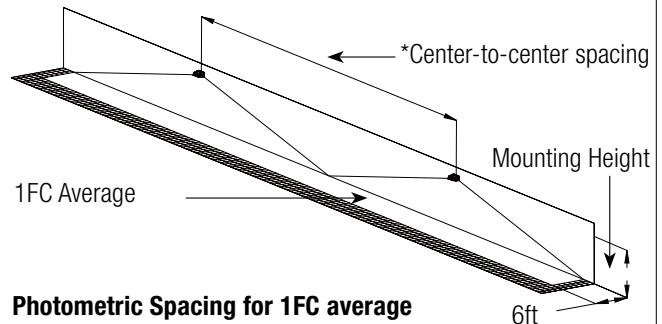

ORDERING FORMAT

SERIES	NUMBER OF HEADS	LED HEAD
SPR= Severe Performance Remote	D= Double head	L6= 12-24V – 6W (565 Lumens) L10= 12-24V – 10W (1000 Lumens) L15= 12-24V – 15W (1300 Lumens)

EXAMPLE: SPRDL6

Easy Installation in Industrial Spaces

Mounts easily on walls, struts, poles and columns

Optional pole mount bracket (PMK1-L) accommodates any square or round post or column.

Supports battery unit weight on pole mount bracket

The battery unit slides into the pole mount bracket so that it stays in position and the weight of the unit is supported during installation.

Uses the same brackets for battery units and remotes

No need to mark which unit goes where for the bracket installers; both units fit the same brackets.

Holds door position with grip hinge

The battery unit access door will hold its position at any angle for easier, hands-free wiring.

Closes and locks door with captive screws

Captive screws keep tightly closed the battery unit and remote head housings hinged door for a perfect NEMA 4X seal.

Allows wiring from the top or side

Both the battery unit and remotes feature side wings for different mounting surfaces and feature top and side 1/2 inch conduit entries.

Optional Pole Mounting Bracket

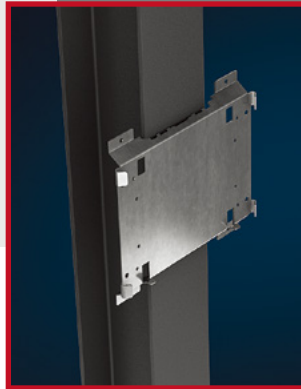

Put mounting bracket in place.



Insert straps into holes.

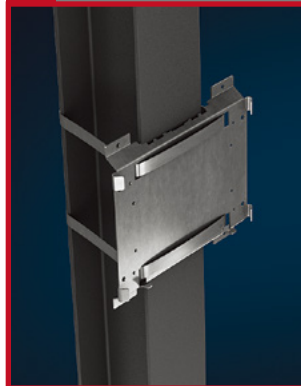

Tighten up.



Insert unit into installed mounting bracket and...



... slide down.



Screw unit on mounting bracket. (Hardware supplied)

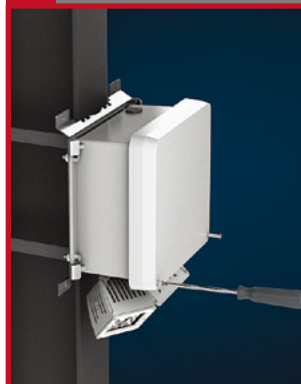

Unscrew access door screws.

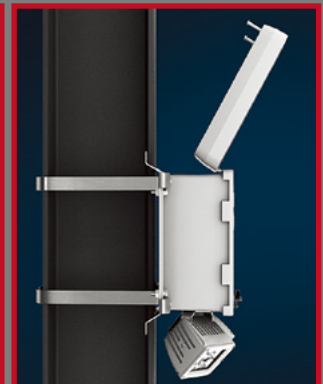

Lift up cover. It stays in place due to the grip system hinge.



Lights the way to safety

A leader in emergency lighting and exit signs in the United States, Lightalarms® provides reliable products using cost-efficient and innovative technologies for all market segments. Lightalarms® strives in servicing fast-track projects for specifiers and contractors with products designed and manufactured in North America.

www.lightalarms.com

All information and specifications contained in this flyer are subject to change due to engineer design, errors and omissions. Illustrations and diagrams within this catsheet may vary from actual products.

© 2016 Thomas & Betts Limited. All rights reserved.
Printed in Canada. 06/16/2000. Order Number: LA-SPFLYER